

Fancoils Ceiling/Floor 2nd Generation

Cased

PRODUCT SHEET



KC-FC-S2

Recommended controller

Product certified by:



FEATURES

Model	KFC-S2E-2T-250D	KFC-S2E-2T-350D	KFC-S2E-2T-500D	KFC-S2E-2T-800D
Cooling capacity	1,19 / 2,35 kW	2,20 / 3,50 kW	2,71 / 4,30 kW	4,57 / 7,35 kW
Heating capacity	1,34 / 2,60 kW	2,19 / 3,50 kW	2,60 / 4,30 kW	4,71 / 8,05 kW
Power input	7 / 17 W	10 / 26 W	14 / 50 W	22 / 113 W
Airflow	190/315/400 m ³ /h	340/470/595 m ³ /h	410/580/790 m ³ /h	685/1.015/1.360 m ³ /h
Sound pressure	29/37/43 dB(A)	37/45/52 dB(A)	43/52/59 dB(A)	49/58/64 dB(A)
Water flow cooling	0,21 / 0,40 m ³ /h	0,38 / 0,60 m ³ /h	0,47 / 0,74 m ³ /h	0,79 / 1,27 m ³ /h
Evaporator pressure drop cool.	4,60 / 13,30 kPa	15,40 / 34,10 kPa	22,80 / 54,20 kPa	19,40 / 44,10 kPa
Evaporator pressure drop heat.	4,50 / 14,30 kPa	14,80 / 35,10 kPa	22,30 / 54,30 kPa	18,20 / 46,90 kPa
Hydraulic connections	Ø3/4"	Ø3/4"	Ø3/4"	Ø3/4"
Power supply	220 V / 1 / 50 Hz			
Power wiring	(2+T)x2,50 mm ²	(2+T)x2,50 mm ²	(2+T)x2,50 mm ²	(2+T)x2,50 mm ²

WIRING DIAGRAM

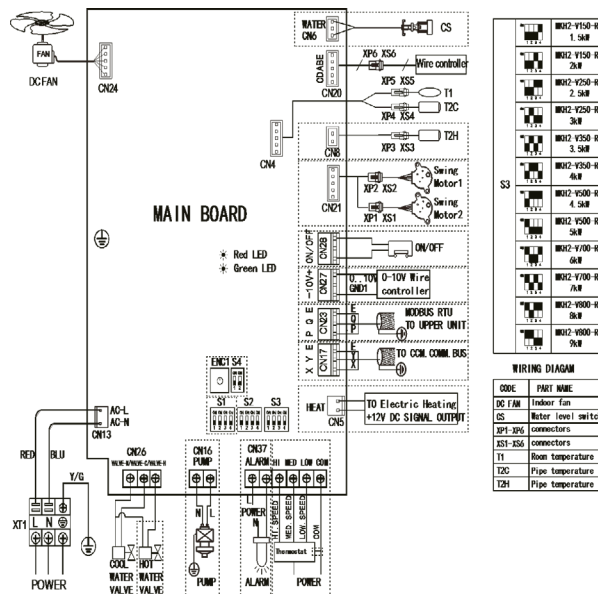

NOTE:
 1. ALARM Port: strong signal when an alarm output.
 2. ON/OFF Port: When connect, the wire controller and Centralized Controller is invalid. System is equivalent of shutdown.

NOTES:

(1) The data and specifications present in this sheet may vary without notice.

(2) The images on this sheet are indicative and may be different from the final machine.

DIMENSIONS & WEIGHT

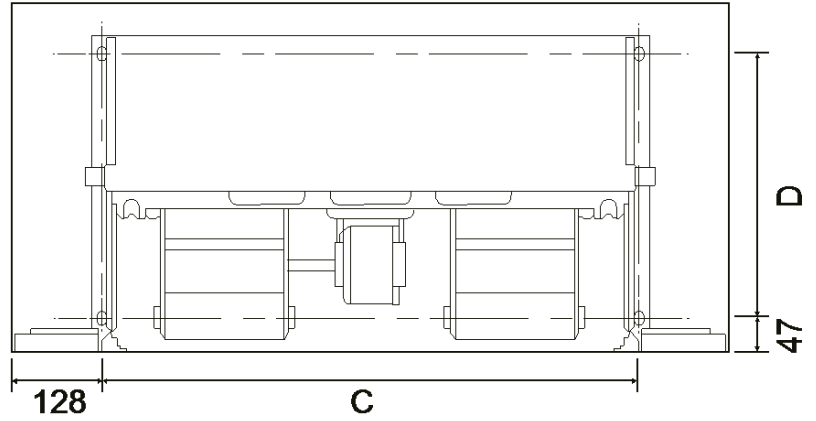
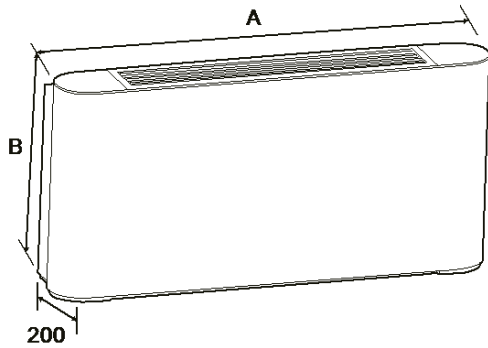

Model	A (mm)	B (mm)	C (mm)	D (mm)	Weight (kg)
KFC-S2E-2T-250D	1.020	495	764	375	21,50
KFC-S2E-2T-350D	1.240	495	984	375	25,50
KFC-S2E-2T-500D	1.240	495	984	375	25,50
KFC-S2E-2T-800D	1.360	495	1.104	391	32,50

INSTALLATION

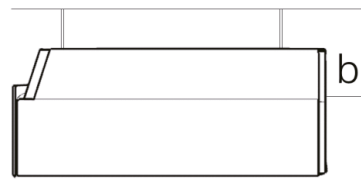
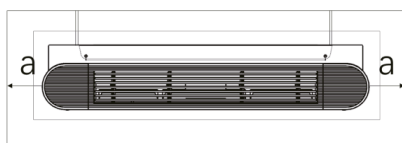
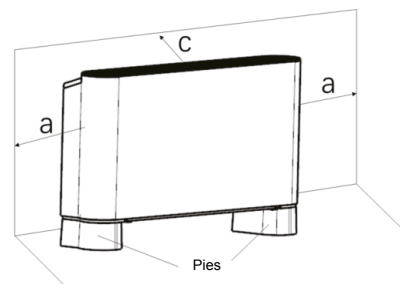
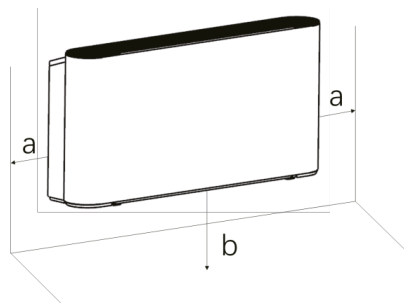

a (mm)	≥ 150
b (mm)	≥ 90
c (mm)	≥ 50

Fancoils Ceiling/Floor 2nd Generation

Uncased

PRODUCT SHEET



KC-FC-S2
Recommended controller

Product certified by:



FEATURES

Model	KFC-S2-2T-250D	KFC-S2-2T-350D	KFC-S2-2T-500D	KFC-S2-2T-500D
Cooling capacity	1,19 / 2,35 kW	2,20 / 3,50 kW	2,71 / 4,30 kW	4,57 / 7,35 kW
Heating capacity	1,34 / 2,60 kW	2,19 / 3,50 kW	2,60 / 4,30 kW	4,71 / 8,05 kW
Power input	7 / 17 W	10 / 26 W	14 / 50 W	22 / 113 W
Airflow	190/315/400 m ³ /h	340/470/595 m ³ /h	410/580/790 m ³ /h	685/1.015/1.360 m ³ /h
Sound pressure	29/37/43 dB(A)	37/45/52 dB(A)	43/52/59 dB(A)	49/58/64 dB(A)
Water flow cooling	0,21 / 0,40 m ³ /h	0,38 / 0,60 m ³ /h	0,47 / 0,74 m ³ /h	0,79 / 1,27 m ³ /h
Evaporator pressure drop cool.	4,60 / 13,30 kPa	15,40 / 34,10 kPa	22,80 / 54,20 kPa	19,40 / 44,10 kPa
Evaporator pressure drop heat.	4,50 / 14,30 kPa	14,80 / 35,10 kPa	22,30 / 54,30 kPa	18,20 / 46,90 kPa
Hydraulic connections	Ø3/4"	Ø3/4"	Ø3/4"	Ø3/4"
Power supply	220 V / 1 / 50 Hz			
Power wiring	(2+T)x2,50 mm ²	(2+T)x2,50 mm ²	(2+T)x2,50 mm ²	(2+T)x2,50 mm ²

WIRING DIAGRAM

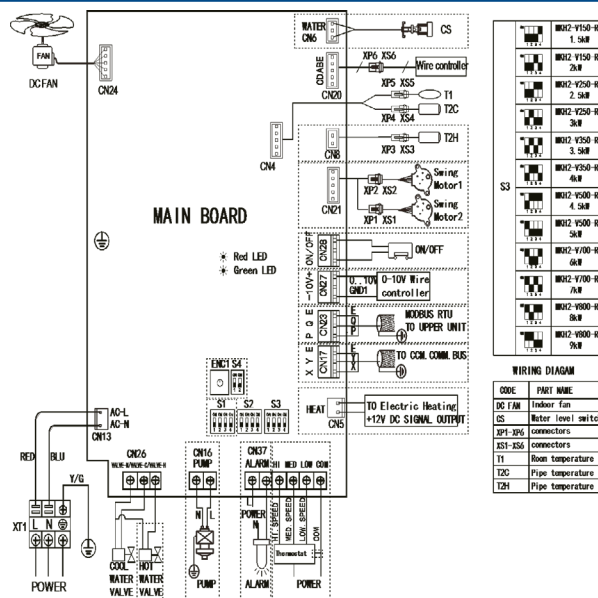

NOTE:
1. ALARM Port: strong signal when an alarm output.
2. ON/OFF Port: When connect, the wire controller and Centralized Controller is invalid. System is equivalent of shutdown.

NOTES:
(1) The data and specifications present in this sheet may vary without notice.
(2) The images on this sheet are indicative and may be different from the final machine.

DIMENSIONS & WEIGHT

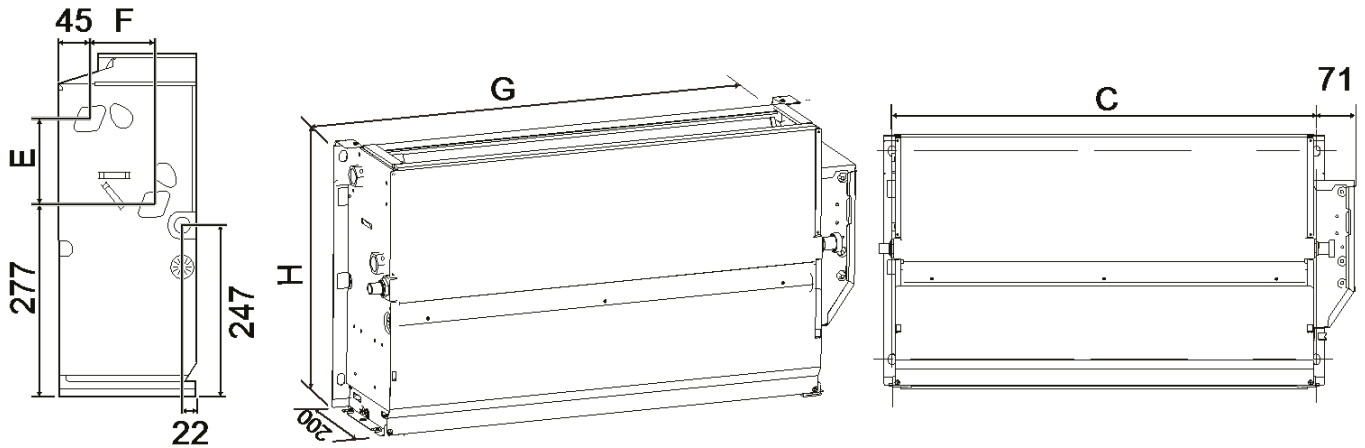

Model	C (mm)	E (mm)	F (mm)	G (mm)	H (mm)	Weight (kg)
KFC-S2E-2T-250D	764	123	93	858	455	16,50
KFC-S2E-2T-350D	984	123	93	1.078	455	19,50
KFC-S2E-2T-500D	984	123	93	1.078	455	19,50
KFC-S2E-2T-800D	1.104	219	102	1.198	551	25

INSTALLATION

