

# Prodigy PRO Multisystem

## PRODUCT SHEET



KID-06 S  
Standard controller

Product certified by:



### FEATURES

Model	KAY-P 26 DR12	KAY-P 35 DR12	KAY-P 52 DR12	KAY-P 71 DR12
Cooling capacity	2,72 kW	3,52 kW	5,28 kW	7,10 kW
Heating capacity	3,13 kW	3,96 kW	5,57 kW	7,33 kW
Airflow	530 / 360 / 280 m <sup>3</sup> /h	560 / 380 / 290 m <sup>3</sup> /h	685 / 580 / 400 m <sup>3</sup> /h	1092 / 724 / 379 m <sup>3</sup> /h
Sound pressure	40 / 32 / 21.5 dB(A)	41 / 34 / 22 dB(A)	41 / 35 / 23 dB(A)	44,5 / 40 / 33 dB(A)
Power supply	220-240 V / 1 / 50 Hz			
Communication wiring	(3+T) x 2,50 mm <sup>2</sup>	(3+T) x 2,50 mm <sup>2</sup>	(3+T) x 2,50 mm <sup>2</sup>	(3+T) x 2,50 mm <sup>2</sup>
Refrigerating pipes	Ø1/4" / Ø3/8"	Ø1/4" / Ø3/8"	Ø1/4" / Ø1/2"	Ø3/8" / Ø5/8"

### WIRING DIAGRAM

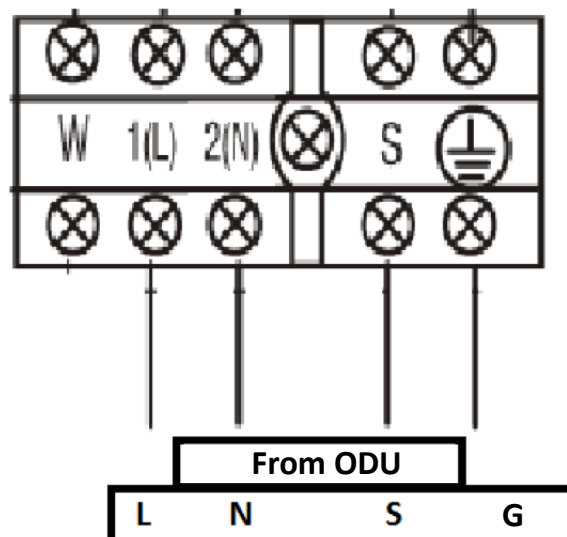

NOTES:

(1) The data and specifications present in this sheet may vary without notice.  
 (2) The images on this sheet are indicative and may be different from the final machine.

## DIMENSIONS & WEIGHT OF INDOOR UNIT

Model	Weight	Width	Height	Depth
<b>KAY-P 26 DR12</b>	10,2 kg	857 mm	231 mm	300 mm
<b>KAY-P 35 DR12</b>	10,2 kg	857 mm	231 mm	300 mm
<b>KAY-P 52 DR12</b>	12,3 kg	1024 mm	246 mm	321 mm
<b>KAY-P 71 DR12</b>	20 kg	1197 mm	280 mm	371 mm

