

Onnix 2.0

Multisystem

PRODUCT SHEET



KID-05.4 S
Standard controller

Product certified by: 



FEATURES

| Model | KAY-D 26 DR11 | KAY-D 35 DR11 | KAY-D 52 DR11 |
|----------------------|-----------------------------------|-----------------------------------|-----------------------------------|
| Cooling capacity | 2,64 kW | 3,52 kW | 5,28 kW |
| Heating capacity | 2,93 kW | 3,81 kW | 5,57 kW |
| Airflow | 700 / 515 / 425 m ³ /h | 700 / 515 / 425 m ³ /h | 750 / 530 / 430 m ³ /h |
| Sound pressure | 40 / 32.5 / 21.5 dB(A) | 40 / 32.5 / 21.5 dB(A) | 41.5 / 36.5 / 33.5 / 19 dB(A) |
| Power supply | 220-240 V / 1 / 50 Hz | | |
| Communication wiring | (3+T) x 2,50 mm ² | (3+T) x 2,50 mm ² | (3+T) x 2,50 mm ² |
| Refrigerating pipes | Ø1/4" / Ø3/8" | Ø1/4" / Ø3/8" | Ø1/4" / Ø1/2" |

WIRING DIAGRAM

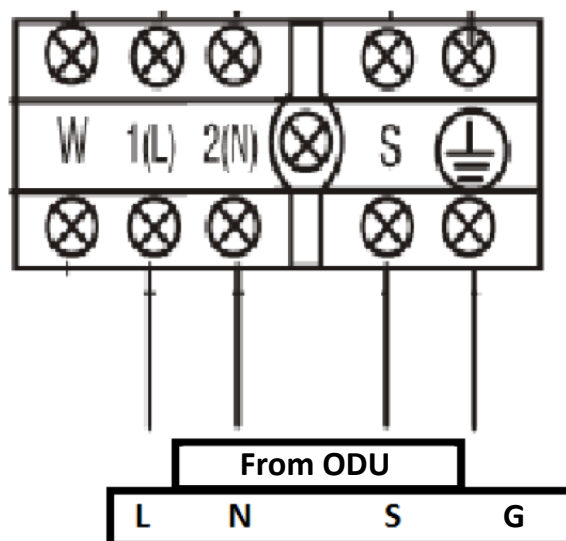

NOTES:
 (1) The data and specifications present in this sheet may vary without notice.
 (2) The images on this sheet are indicative and may be different from the final machine.

DIMENSIONS & WEIGHT OF INDOOR UNIT

| Model | Weight | W | H | D |
|----------------------|----------|--------|--------|--------|
| KAY-D 26 DR11 | 11,30 kg | 920 mm | 211 mm | 321 mm |
| KAY-D 35 DR11 | 11,30 kg | 920 mm | 211 mm | 321 mm |
| KAY-D 52 DR11 | 11,30 kg | 920 mm | 211 mm | 321 mm |

