

# Cassettes 600x600 & 840x840

## Multisystem

## PRODUCT SHEET



KID-06 S  
Standard controller

Product certified by: 



## FEATURES

Model	KCI-20 DMR15	KCI-26 DR15	KCI-35 DR15	KCI-52 DR15	KCIS-71 DR14
Cooling capacity	2,05 kW	2,63 kW	3,52 kW	5,28 kW	7,03 kW
Heating capacity	2,64 kW	2,93 kW	3,81 kW	5,57 kW	7,62 kW
Airflow	330/520/620 m <sup>3</sup> /h	330/520/620 m <sup>3</sup> /h	330/520/620 m <sup>3</sup> /h	300 / 540 / 660 m <sup>3</sup> /h	1.000/1.140/1.300 m <sup>3</sup> /h
Sound pressure	31.5 / 38.5 / 42	31.5 / 38.5 / 42 dB(A)	31.5 / 38.5 / 42 dB(A)	31.5 / 38.5 / 42 dB(A)	39,5/42,5/45,5 dB(A)
Power supply	220-240 V / 1 / 50 Hz				
Communication wiring	(3+T)x2,50 mm <sup>2</sup>	(3+T)x2,50 mm <sup>2</sup>	(3+T)x2,50 mm <sup>2</sup>	(3+T)x2,50 mm <sup>2</sup>	(3+T)x2,50 mm <sup>2</sup>
Refrigerating pipes	Ø1/4" / Ø3/8"	Ø1/4" / Ø3/8"	Ø1/4" / Ø3/8"	Ø1/4" / Ø1/2"	Ø3/8" / Ø5/8"

## WIRING DIAGRAM

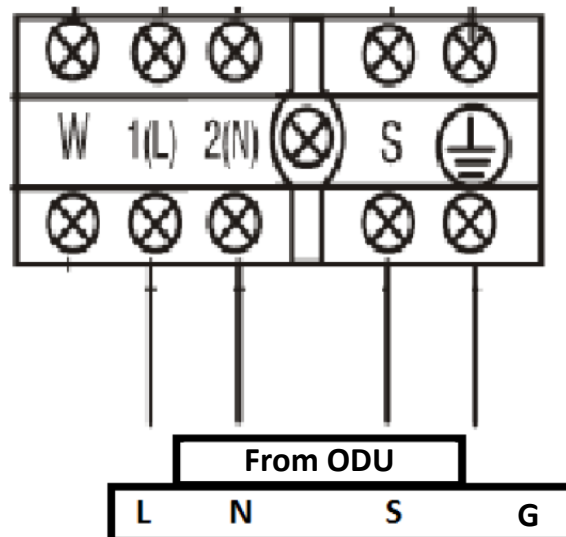

NOTES:  
 (1) The data and specifications present in this sheet may vary without notice.  
 (2) The images on this sheet are indicative and may be different from the final machine.

## DIMENSIONS & WEIGHT OF INDOOR UNIT

Model	Weight
<b>KCI-20 DMR15</b>	16.10 kg
<b>KCI-26 DR15</b>	16.10 kg
<b>KCI-35 DR15</b>	16.10 kg
<b>KCI-52 DR15</b>	16.20 kg

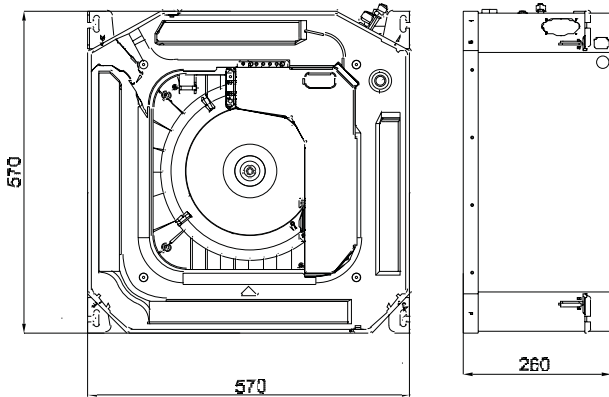

Model	Weight
<b>KCIS-71 DR13</b>	21,60 kg

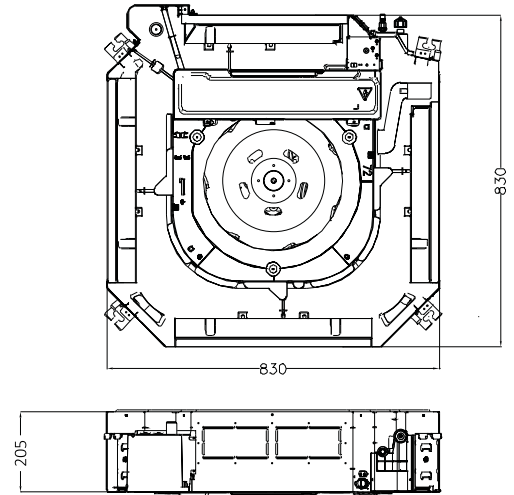

## DIMENSIONS & WEIGHT OF PANEL

Model	Weight
<b>KPA-03B 600x600</b>	2,50 kg

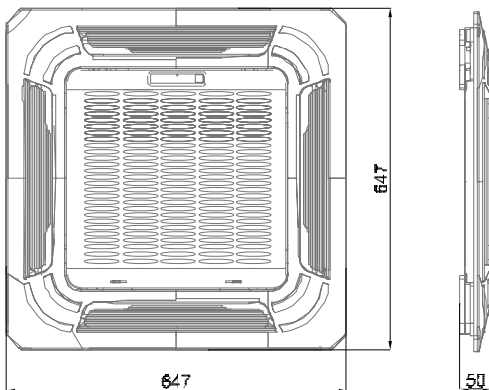

Model	Weight
<b>LCAC KPA4-04B 840x840</b>	6 kg

