

Cassette 600x600

2 Pipes



KI-04 S

Recommended controller

Product certified by:



FEATURES

Model	KFC-CI-2T-300D1	KFC-CI-2T-500D1
Cooling capacity	2 / 2,98 kW	3,01 / 4,20 kW
Heating capacity	2,24 / 2,61 kW	3,26 / 4,95 kW
Power input	5 / 15 W	21 / 43 W
Airflow	322/429/535 m ³ /h	494/611/781 m ³ /h
Sound pressure	27/33/39 dB(A)	32/38/43 dB(A)
Water flow cooling	0,35 / 0,53 m ³ /h	0,54 / 0,75 m ³ /h
Evaporator pressure drop cool.	5 / 10 kPa	7,40 / 12,30 kPa
Evaporator pressure drop heat.	5,30 / 12,10 kPa	6,10 / 9,40 kPa
Hydraulic connections	Ø3/4"	Ø3/4"
Power supply	220-240 V / 1 / 50 Hz	
Power wiring	(2+T)x2,50 mm ²	

WIRING DIAGRAM

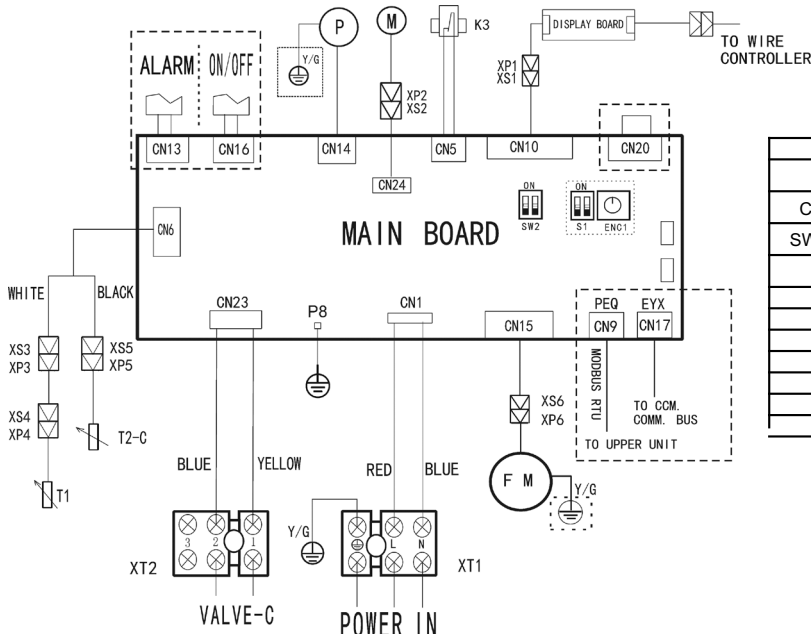

CODE	PART NAME
XT1-2	3-WAY TERMINAL
CN1-22, P1-8	P.C. BOARD SOCKETS
SW2, S1, ENC1	SWITCH
FM	INDOOR FAN MOTOR
K3	WATER LEVEL SWITCH
M	SWING MOTOR
P	PUMP
T1	ROOM TEMPERATURE
T2-C	PIPE TEMPERATURE
XP1-6	CONNECTORS
XS1-6	CONNECTORS

NOTES:

- (1) The data and specifications present in this sheet may vary without notice.
 (2) The images on this sheet are indicative and may be different from the final machine.

DIMENSIONS & WEIGHT

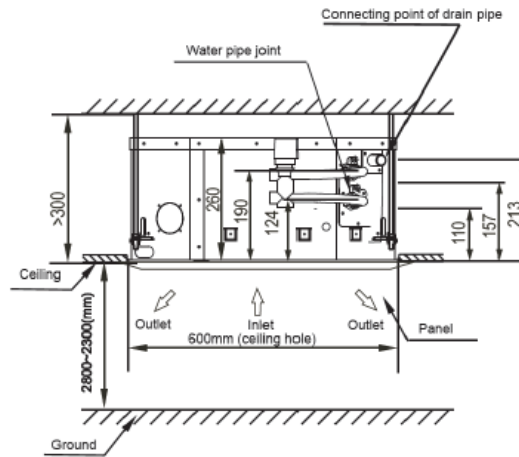
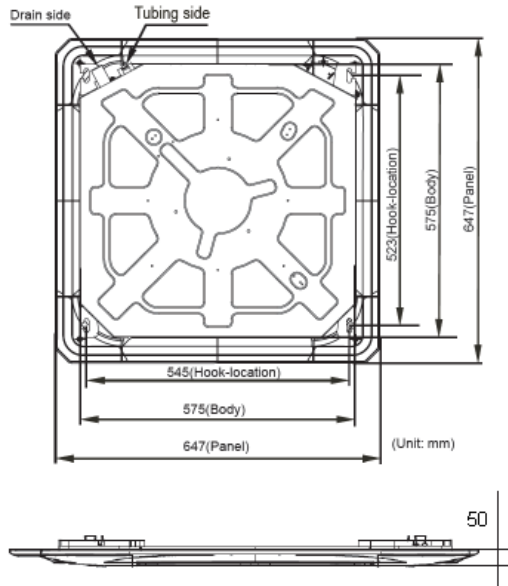

Model	Weight	Weight Panel
KFC-CI-2T-300D1	16,50 kg	2,50 kg
KFC-CI-2T-500D1	16,50 kg	2,50 kg