

High Pressure Ducts

PRODUCT SHEET



HID-Ti10
Recommended thermostat
for 2 and 4 pipes

Product certified by: **CE**



FEATURES 2 TUBES

Model		FHDE-130	FHDE-220	FHDE-230	FHDE-240	FHDE-330
Cooling capacity max.	kW	8,83	12,16	15,36	17,99	21,35
Sensitive cooling capacity max.	kW	6,74	9,91	12,24	16,67	17,34
Heat output max.	kW	8,03	14,37	17,79	18,81	25,34
Air flow rate max.	m ³ /h	1550	2800	3050	2900	4450
Sound pressure low/average/high	dB(A)	17/39/51	18/41/52	19/42/53	19/42/53	16/43/55
Net weight	kg	39	49	55	58	71
Max. static pressure	Pa	150	150	150	150	150
Cooling/hot water connections	inch	3/4"	3/4"	3/4"	3/4"	3/4"

FEATURES 4 TUBES

Model		FHDE-131	FHDE-221	FHDE-231	FHDE-321	FHDE-331
Cooling capacity max.	kW	8,62	11,84	14,86	16,54	20,76
Sensitive cooling capacity max.	kW	6,54	9,66	11,75	13,75	16,75
Heat output max.	kW	7,36	12,42	13,04	17,57	18,36
Air flow rate low/average/high	m ³ /h	1490	2700	2900	3950	4250
Sound pressure low/average/high	dB(A)	17/39/51	18/41/52	19/42/53	19/42/53	16/43/55
Net weight	kg	41	56	58	73	75
Max. static pressure	Pa	150	150	150	150	150
Cooling/hot water connections	inch	3/4" - 1/2"	3/4" - 1/2"	3/4" - 1/2"	3/4" - 1/2"	3/4" - 1/2"

WIRING DIAGRAM

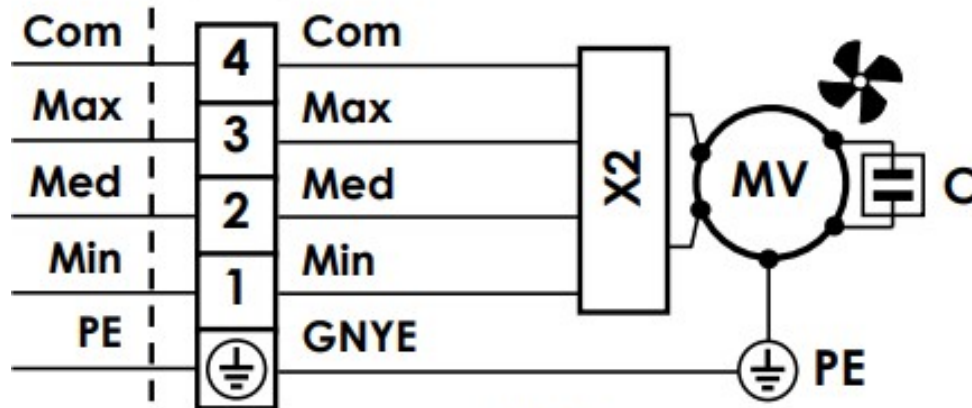

Model	FHDE-130/ FHDE-131	FHDE-220/ FHDE-221	FHDE-230/ FHDE-231	FHDE-240	FHDE-330/ FHDE-321/ FHDE-331
No. of fans	1	2	2	2	3
Consumption	180 W	400 W	400 W	400 W	550 W
Max. current	1,40 A	1,80 A	1,80 A	1,80 A	2,50 A
Voltage	230Vac-1Ph-50/60Hz				

DIMENSIONS

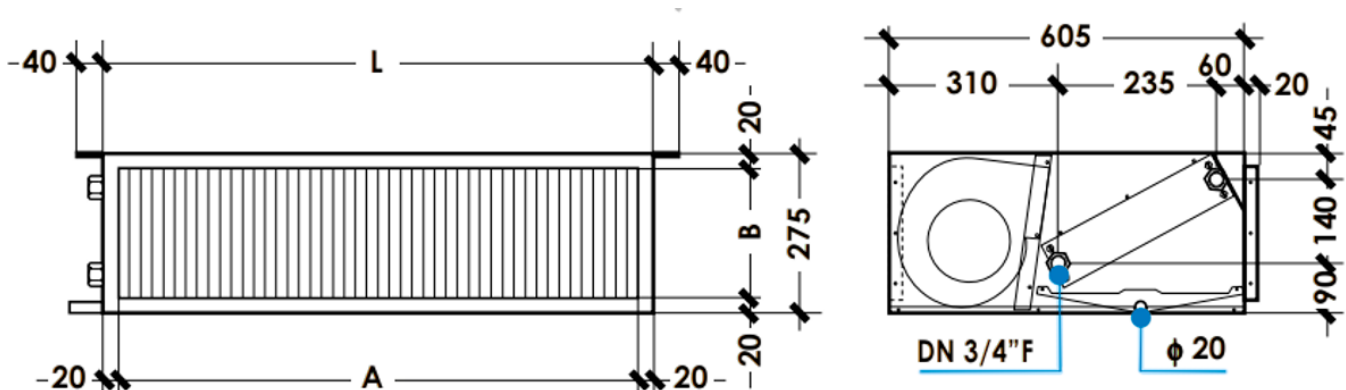

Model	FHDE-130/ FHDE-131	FHDE-220/ FHDE-221	FHDE-230/ FHDE-231	FHDE-240	FHDE-330/ FHDE-321/ FHDE-331
L	800 mm	1200 mm	1200 mm	1200 mm	1600 mm
A	760 mm	1160 mm	1160 mm	1160 mm	1560 mm
B	235 mm	235 mm	235 mm	235 mm	235 mm

*With the K1 panel, the width and height are increased by 40mm.